

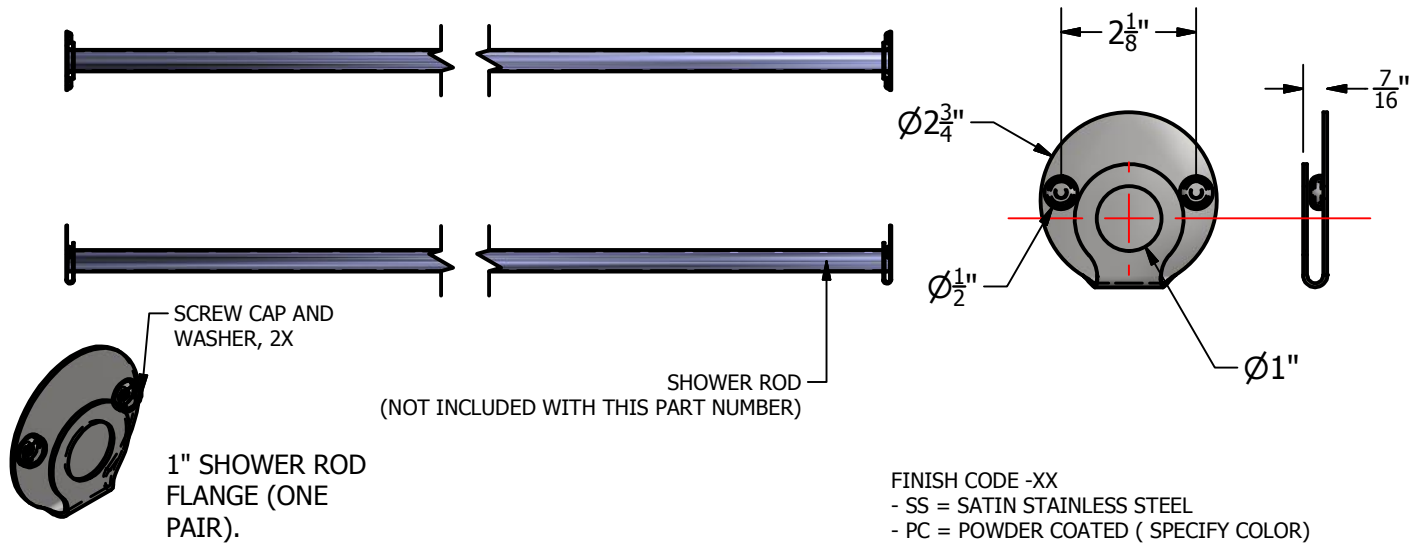

# Technical Data Sheet

S-3060-XX  
1"Ø SHOWER ROD FLANGES



DATA CURRENT AS OF: 1/18/2013

## CONSTRUCTION:

FLANGES (2): 16 GAUGE TYPE 304 STAINLESS STEEL, FORMED ONE PIECE.  
 SCREW: #8 WOOD X 1 1/2" LONG PHIL. PAN HEAD. 18-8 STAINLESS STEEL.  
 SCREW CAP: ELECTROPLATED SATIN CHROME SNAP-CAP.  
 WASHER: FLAT BOTTOM PLASTIC SNAP-CAP.

## INSTALLATION:

FASTEN ONE FLANGE TO WALL USING THE SUPPLIED SCREWS THROUGH THE SNAP-WASHER AND APPROPRIATE WALL ANCHORS (NOT SUPPLIED).  
 INSERT SHOWER ROD AND REPEAT FOR OTHER FLANGE.  
 PRESS ON THE SNAP-CAPS ONTO THE WASHER/SCREW UNTIL THEY SNAP INTO PLACE.

NOTE: SHOWER ROD FLANGES AND SHOWER ROD IS ONLY AS STRONG AS THE ANCHORING DEVICES AND THE WALL ON WHICH IT IS MOUNTED TO.

## GUIDE SPECIFICATION:

FORMED ONE PIECE FLANGE FOR 1"Ø TUBE.  
 16 GAUGE TYPE 304 STAINLESS STEEL.  
 PART NUMBER INCLUDES ONE PAIR, SHOWER ROD IS NOT INCLUDED WITH THIS PART NUMBER.  
 FINISHES AND BAR LENGTH AS INDICATED.

Brey-Krause Mfg. reserves the right to make changes in design and/or material without formal notice and without incurring any obligation.

**BREY-KRAUSE  
MANUFACTURING**  
© 2012

BREY-KRAUSE MANUFACTURING  
 1209 W. Lehigh Street, Bethlehem, PA 18018  
 Phone: 610-867-1401 Fax: 610-866-1433  
 www.brey-krause.com